

The RAD-TEL RT8000 Series

- The Latest Generation Control Equipment from the Pioneers of Radio Telemetry in Australia
- Highly Expandable Hardware
- Flexible Software
- Remotely Configured
- Remotely Upgraded
- Backwards Compatible
- Intelligent
- Based on 30 Years experience in Radio Communications and Telemetry



An astounding list of features for a Single Control Product:

- Event Initiated Change-Of-State reporting on BOTH Analog and Digital Inputs.
- In-built File Transfer Protocol that incorporates encryption and compression to allow Protocols, Control Functions, Firmware, System Logs and Historical Data to be transferred or upgraded remotely through UHF/ VHF Radio, LAN or CDMA networks.
- Ultra Sonic Level Measurement removing the necessity to have any items below Water Level resulting in less maintenance and a much greater range of Level Increments. (Also Float and Transducer compatible)
- In-built standard control functionality including Lead/Lag Pump Operation and Auto Standby Change-over on Fault as well as Duty Cycle Rotation based on a wide variety of optional parameters. Custom control loops can be written in a variety of languages including Ladder Logic, C, C++, BASIC and downloaded to the RTU.
- Both Up Stream Inhibiting and Down Stream Acceptance Check before pumping ensures maximum protection against undesired environmental discharges.
- Upgrading early Pump Stations can be as simple as connecting the RT8000 directly to the Run Contactors.
- Analog and Digital History such as Pump Starts, Run Time Information, Motor Currents etc. are all stored in the RTU and can be uploaded to the Master Station 'over air' for Data Analysis, Graphing and Archiving.
- In the event of a Repeater failure (e.g. lightning strike) the RT8000 can switch its own radio channels and attempt to contact critical control sites via a back-channel.
- The CDMA Mobile Network can be used as a communications back-up for the Radio Network and critical control can be automatically switched to CDMA in the event of radio failure. SMS Alarm Messages can also be sent directly from Critical Sites via this Network

Figure 1:

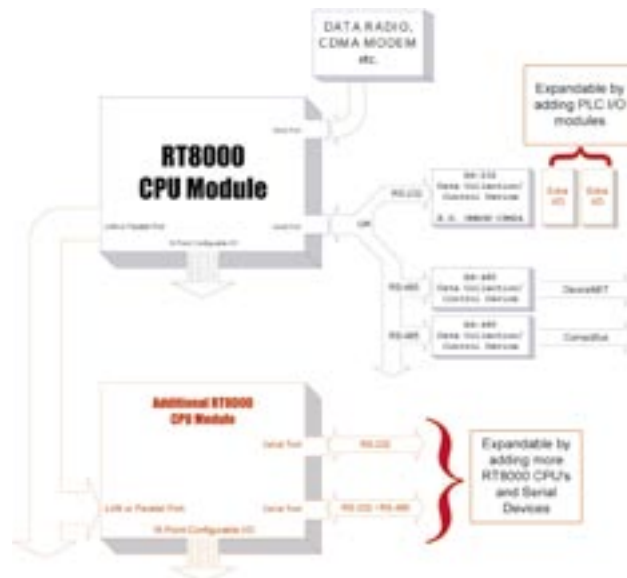

The modular design enables highly flexible hardware configurations to be customised or expanded quickly and easily to suit the application.

The RAD-TEL RT8000 Series

The **RAD-TEL RT8000** Series is the latest in a long line of **RAD-TEL** RTU's. The RT8000 Series is designed specifically to address the need for a Telemetry product that utilises field-proven communication protocols, whilst having all the functionality expected from a PLC based RTU product and more! While the RT8000 has been designed utilising the wide range of PLC's offered by OMRON, the product is capable of communicating with many other local Serial (RS-232 or RS-485), LAN and Parallel Devices (Figure 1). The RT8000 also boasts software configurable on-board I/O and an encrypted File Transfer Protocol (Figures 2 and 3) that incorporates high compression to allow Protocols, Control Functions, Firmware, System Logs and Historical Data to be transferred or upgraded remotely through one of many network connection options including UHF/VHF radio, LAN and CDMA.

The fully programmable RTU allows a peripheral device (such as a PLC) programme to be uploaded or downloaded from the SCADA Master Stations. Debugging and control information is readily accessible to remotely implement and test any modifications. The advanced communication features also include the RTU's artificial intelligence which, among other functions, allows system control to continue based on previously accumulated data if a communication failure occurs. This RTU is the most flexible, expandable and reliable product yet. Combined with continual development from **RAD-TEL**, utilising the remote upgrade capability, and new features such as 400 MHz data rates of 19.2Kbps just around the corner, this is the perfect Telemetry Solution for any System.

Figure 2:



The File Transfer Protocol allows Protocols, Control Functions, Firmware, System Logs and Historical Data to be transferred or upgraded remotely. In-built encryption and compression algorithms result in high security and fast transfer times.

Figure 3: File Transfer Protocol User Interface

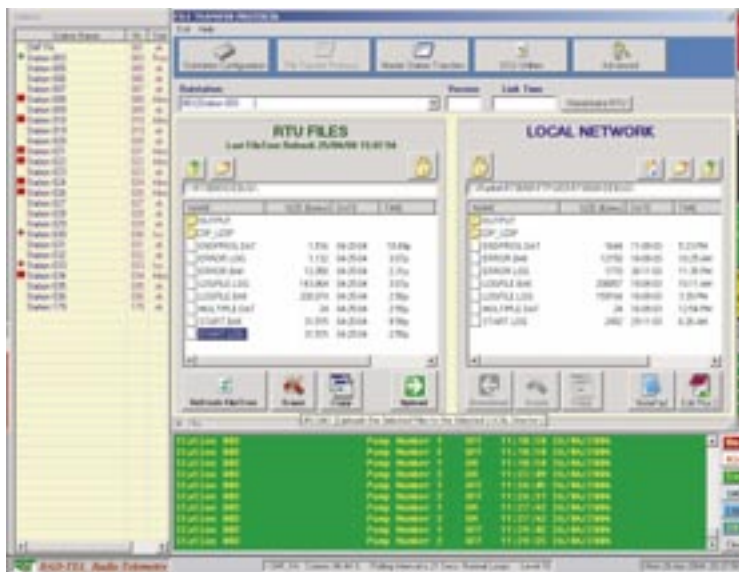

File Transfer Protocol User Interface

RT8000 - SEWERAGE PUMP STATION CONTROLLER

- An RT8000 is installed at Sewerage Pump Station 11 in the Sewerage Network shown:

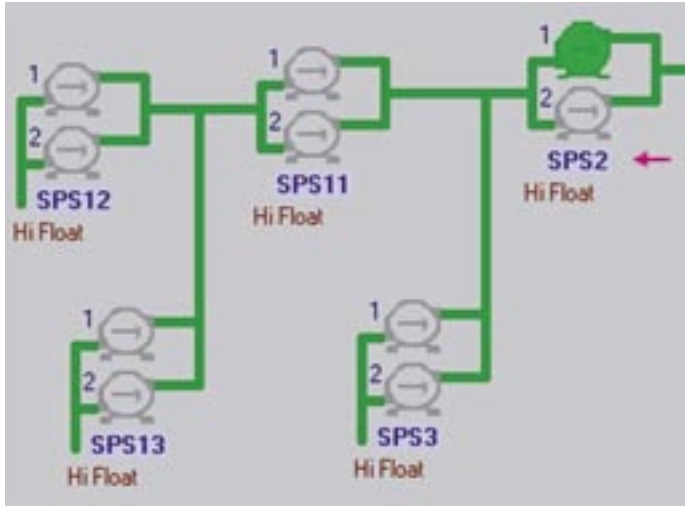

- The RT8000 is supplied with an OMRON PLC **pre-programmed to operate the two-pump Sewerage Pump Station based on floats and/or transducer levels.**
- The PLC program implements **alternate duty pump starts and auto change-over on fault conditions.** Duty change-overs can be set-up to occur at every start, once a week, once a day, every 10 starts or virtually any other condition by programming in the selection criteria.
- The RT8000 reports in all desired event-initiated Change-of-States via the chosen network with **all control settings configurable remotely.**
- Internal alarms are generated automatically** in the RT8000 when too many starts occur over a given period of time (usually indicative of floats being too close) or when a pump runs for too long. These alarms can be reported back to the operator directly via SMS.
- These **alarms are fully configurable and other internally generated alarms or flags can be programmed to the RTU from the Master Station** if desired.
- The RT8000 can also be programmed to **monitor downstream (SPS 2) and adjacent (SPS 3) pump runs and alarms to ensure the downstream station is not overloaded.**

In the event of a dual pump failure or power failure:

- The RT8000 continues to operate due to its **battery-backed power supply.**
- The RT8000 **immediately notifies the operator** through the RAD-TEL network of the pump/power failure via alarm screens, SMS or paging.
- If the "Well High Level" float is activated during the fail time (which is likely as pumps will not be running to empty the well) the RT8000 will **contact the desired upstream Pump Stations and inhibit their pumps to avoid an undesired environmental discharge.** In this example the RT8000 would be programmed to inhibit SPS 12 and SPS 13.
- When the well drops down to an acceptable level the **RT8000 will release the inhibit on the upstream pump stations.**

RT8000 - WATER PUMP STATION CONTROLLER

- An RT8000 is installed at a Water Pump Station and is configured to monitor the reservoir through peer-to-peer communications either directly or via a Repeater.
- The RT8000 controls the Pump Station based on set-points, the reservoir information and other control information stored in the RTU.
- If multiple pumps are present at the Pump Station they can be set-up on an **alternate duty start system** and configured so that the duty pump changes on every start, once a day, once a week etc.
- All set-points and control information may be configured remotely via a Master Station if the stations are part of a larger system.

In the event of a dual pump failure or power failure:

- The RT8000 can continue control of the pumps based on historical data gathered from the reservoir and/or settings programmed into the RT8000
 - Automatic pump control based on:
 - Last known reservoir level
 - Pump flow rate
 - Reservoir capacity
 - Control set-points
 - Estimated reservoir outflow rate
 - The RT8000 can work through a number of pump cycles with no communication whatsoever depending on settings such as the progressively implemented safety margin for estimated pump control.
 - The safety margin system essentially varies the control set-points in a 'safe' direction to avoid reservoir overflow or low level states during this type of estimated pump control.

